

# ENERGY SAVING FOR WINDOWS

Correctly chosen, well positioned and protected windows will save you money and increase the comfort of your home all year round.

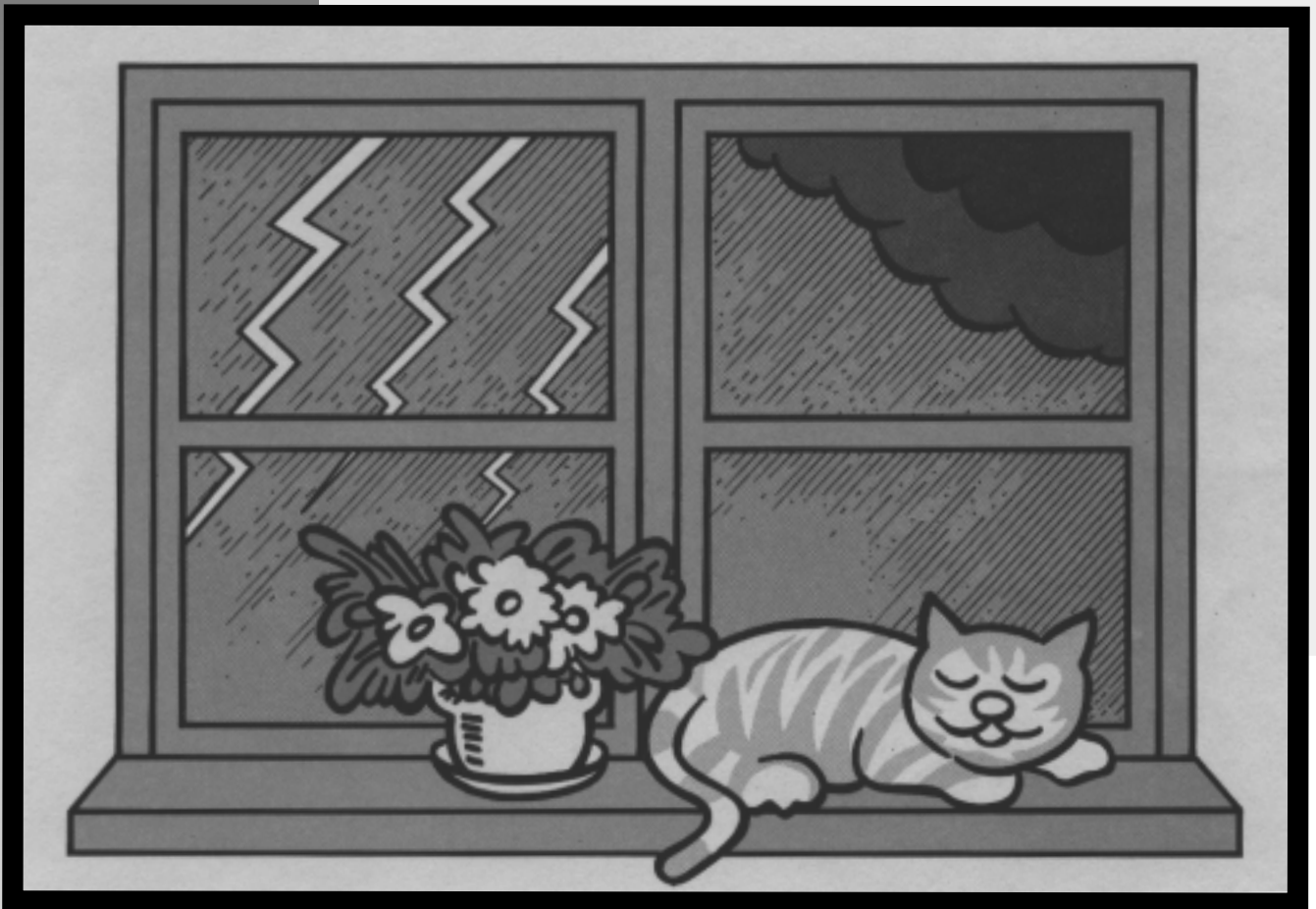

Windows are critical to the overall energy efficiency of a home - as much as 40% of heat entering in summer and 30% of heat lost in winter occurs through windows.



# WINDOWS

The climatic region and the direction windows and other glazed areas face are important factors in determining the appropriate window for your home.

- In warm and humid coastal climate regions, casement, hopper and louvre windows allow greater access to cooling breezes. These types of windows can direct the breeze into and through the home. Glazed areas should be shaded all year.
- In sub-tropical climates, glazed areas should be shaded from October to March to provide sun protection, then allow sun access in winter.
- In temperate regions, north facing glazing should be shaded during summer months, while allowing sun access in winter.
- Homes in northern areas of inland regions would benefit from small windows that are well shaded all year. Windows in southern inland homes require access to winter sun but should be shaded during the summer months.

## SUMMER SHADING

- It is more effective to block the sun's heat from reaching the glass than to deal with the problem once the heat has entered your home. See Figure 1.
- External shading is much more effective at keeping your home cool than internal blinds or curtains.
- Using both external and internal window coverings will provide the greatest protection but will make the room dark. Unused rooms should have curtains and blinds closed during the day.
- The most appropriate method of shading your windows depends upon the direction they face.

### Shading North Facing Windows

- North facing windows should be shaded with devices that provide protection against the summer sun and, where required, allow the sun to enter the house in winter. This requires a degree of flexibility which can be achieved by:
  - Opaque fabric or blinds on pergola frames (see Figure 2);

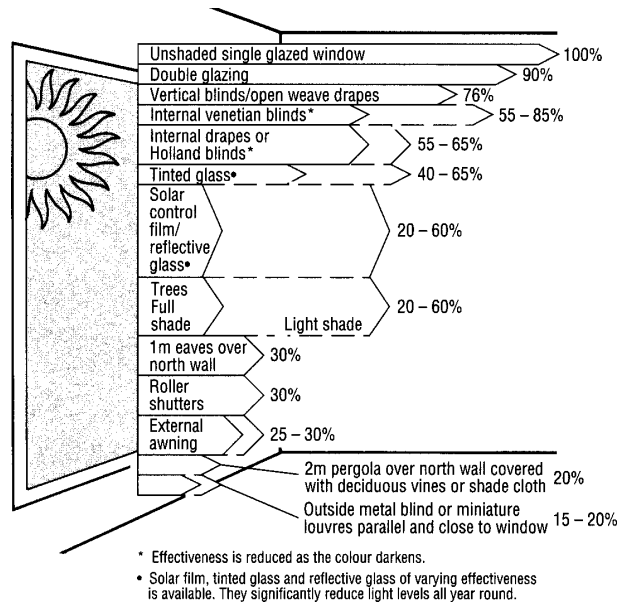

Figure 1 - Comparison of heat gains in summer

- Deciduous vines on pergolas; and
- Removable or adjustable vertical shading such as awnings, blinds and shutters.

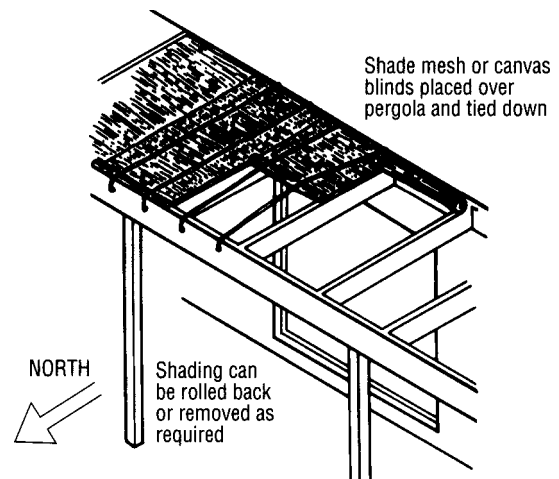

Figure 2 - Shade mesh over a pergola frame

- If properly designed, eaves and pergolas can provide adequate shade from the high summer sun while allowing winter sun to enter and warm your home.

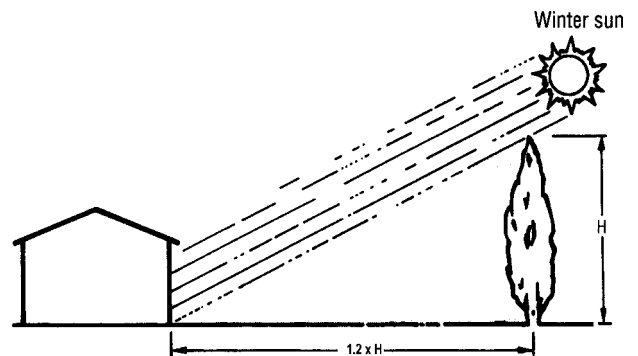

Figure 3 - Shadow cast at midday in mid winter

- Avoid planting large evergreen trees close to the northern windows of your home. In mid-winter, they cast a shadow of up to 1.2 times

their height, cutting the amount of heat and light entering the home (see Figure 3). In northern Queensland, however, the sun has an altitude of 50°, so trees and buildings will only cast a shadow 0.8 times their height.

### Shading East and West Facing Windows

- Eastern and western windows should be well shaded from the morning and afternoon summer sun.
- Adjustable vertical shading covering the entire face of the window are most suitable, for example, awnings, blinds and shutters. See Figure 4.

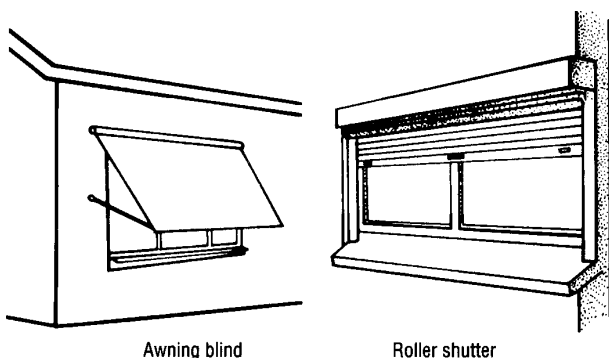

Figure 4 - Adjustable shading for east and west windows

- Fixed vertical shading such as louvres, fences and walls can provide summer shading but will block out views and winter sunlight.
- Horizontal-type shading such as pergolas, eaves and verandahs may not provide adequate shading from the low rising or setting sun.
- Tall, dense trees and shrubs to the south east and south west of the windows will provide shade from the early morning and late afternoon summer sun. See Figure 5.

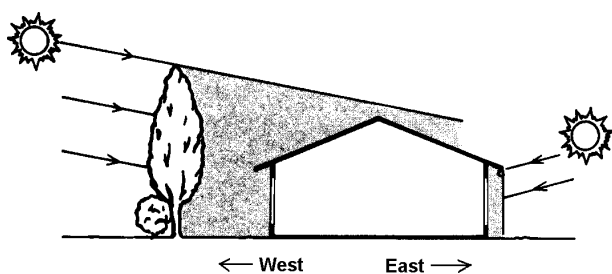

Figure 5 - Blinds or trees will provide suitable shading for eastern and western windows

### Shading for Other Windows

- Windows facing north-east or north-west are best shaded by adjustable awnings or blinds, combined with horizontal shading such as eaves and pergolas.
- South facing windows may require shading from the low-angled early morning or late afternoon summer sun. North of the Tropic of Capricorn, south facing windows will require horizontal shading as the sun is in the southern sky during summer. Eaves with additional vertical shading such as adjustable blinds or trees and bushes are suitable.
- Double glazing reduces non-radiant heat gains from direct sunlight when well shaded in summer, but will not stop direct sunlight entering the home.

### PREVENTING WINTER HEAT LOSS

- Appropriate window protection can reduce heat loss through windows by up to half, reducing your heating bills significantly. See Figure 6.

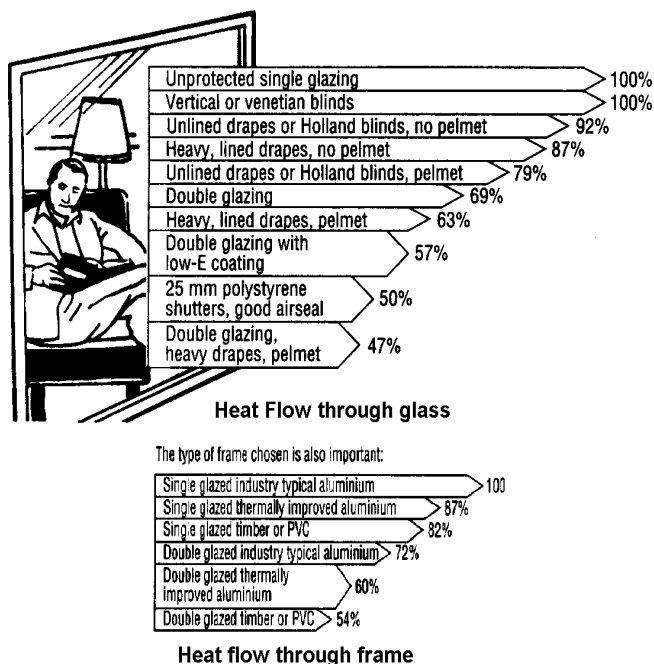

Figure 6 - Comparison of heat loss in winter

- Bare, unprotected glass causes heat loss, discomfort and condensation during winter. See Figure 7 on next page.
- Reflective films and tinted glass have no effect in reducing winter heat loss and will reduce internal light levels all year round.

- Low-E glass (low emissivity glass) has a coating that reflects radiant heat back into the room. It is only available for double glazed windows and improves performance by up to 20% compared with standard double glazing.

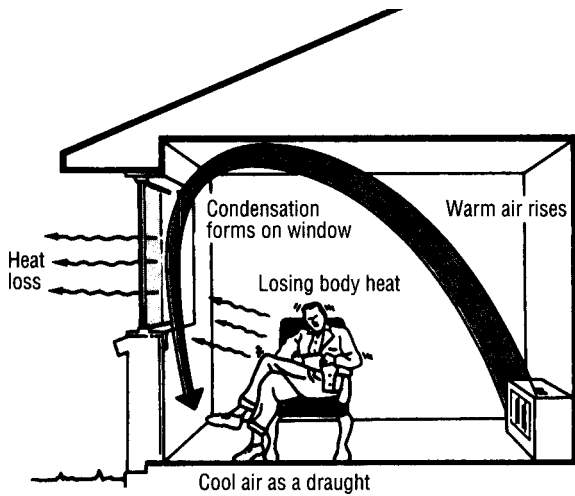

Figure 7 - Heat loss through windows

### Double Glazing

- This type of window consists of two panes of glass separated by a sealed air space typically between 6 mm and 20 mm. A minimum air-space width of 9 mm is recommended. See Figure 8.

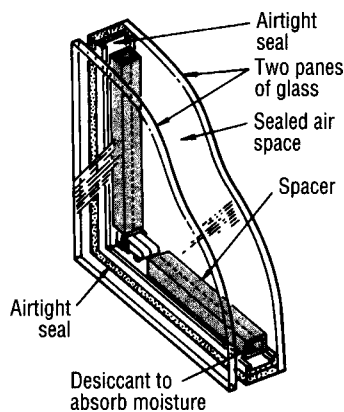

Figure 8 - Section through a typical double glazed unit

- Heat loss is reduced by double glazing as is noise transmission and condensation on the inside pane.
- Double glazing allows natural light and views and is especially crucial for windows not covered with close-fitting drapes or blinds.

### Internal Blinds and Curtains

- Closely woven curtains and close-fitting curtains are an effective way to reduce heat loss at night. They also provide extra summer protection,

especially with reflective linings, and of course provide privacy.

- A snug fit on both sides of the window and boxed pelmets or solid strips at the top of the curtain will stop warm air from moving behind the curtain and cooling down when contacting the cold glass. See figure 9.

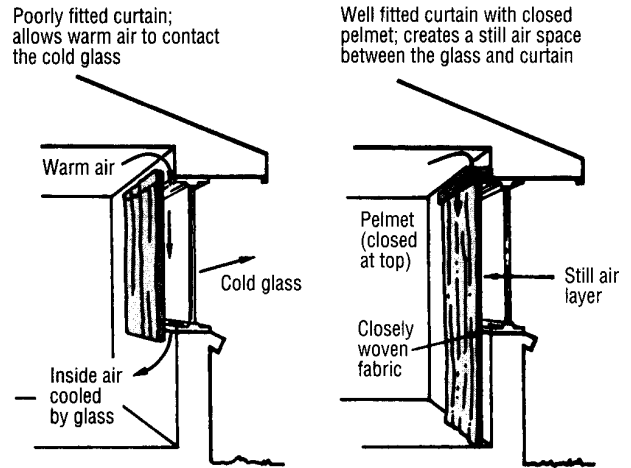

Figure 9 - Features of an effective internal window covering

- Curtain tracks that provide a return of curtain to the wall provide an effective seal against heat loss. Consider attaching the curtains to the window frames by using pins, hooks or velcro.
- Tightly fitting Roman type blinds using closely woven fabrics are suitable for reducing heat loss. See Figures 10 and 11. Blinds must be tightly fitted against the window surrounds. Loose-fitting blinds are not suitable.

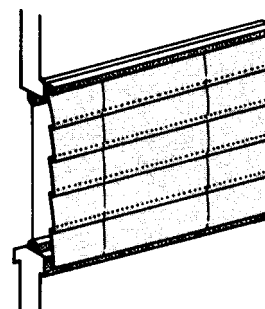

Figure 10 - Roman blind

- Insulated shutters installed on the inside or outside of the window, should fit tightly against the window frame, forming a sealed air space. PVC, polystyrene and solid timber shutters can be used if they shut tightly and are not louvered.
- Louvre, venetian and vertical blinds are not good insulators. They allow heated air to pass through the gaps and make contact with the cool glass.

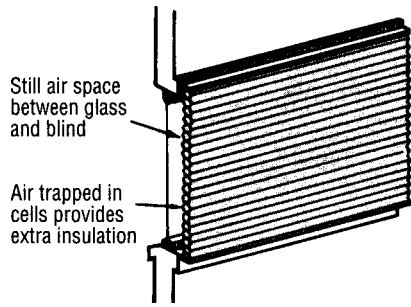

Figure 11 - Multi-cell pleated blinds can be good window insulators

- Laminated glass or thickened glass has minimal effect in reducing winter heat transfer, although it can reduce noise transmission.

## EAVES AND PERGOLAS

- In southern Queensland, the width of north facing eaves or pergola shading should be approximately 50% of the vertical height from the window sill to the underside of the horizontal shading, see Figure 12.

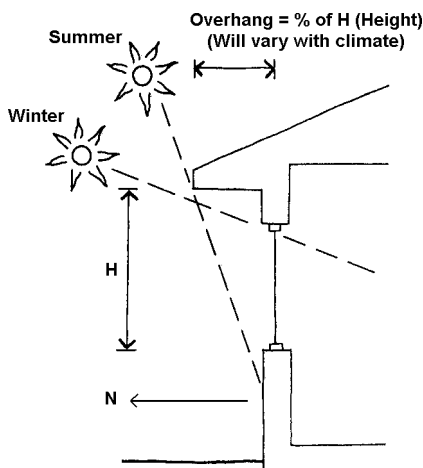

Figure 12 - Determining width of north facing eaves

- In north Queensland, wider eaves are desirable to shade windows all year. South facing windows will also require protection from the midday summer sun.

## Pergolas with Angled Louvres

- Adjustable louvres are preferable to fixed louvres because they provide the flexibility to control the amount of sunlight and shade.
- Fixed louvres should be angled at 40° in southern Queensland and about 50° for northern Queensland. This will let in the mid-winter sun and allow sunlight through upper parts of the windows. (Figure 13).

- Most of the summer sun will be blocked out if louvres overlap. They will also reduce the amount of early autumn and late spring sunlight.
- Louvres should be as thin as possible to allow maximum sunlight penetration when required.
- Like eaves and shade battens, fixed louvres should not extend out further than the recommended horizontal shading overhang or they will cause excessive winter shading.

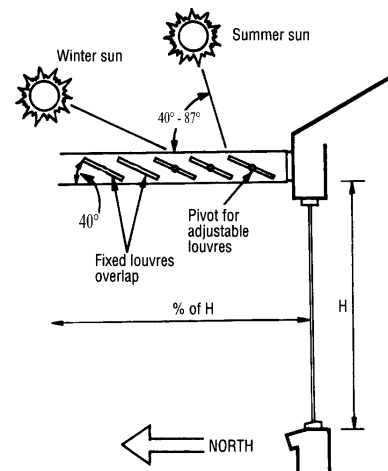

Figure 13 - Louvres angled at 40°

- Wide verandahs are not recommended over north facing windows except in northern Queensland, as they generally don't allow adequate winter sun to enter the home.
- If considering using verandahs, modifications like cutting back their width or installing transparent roofing, e.g. polycarbonate sheeting, can allow more winter light through.



## TINTED GLASS AND REFLECTIVE FILMS

- These glass treatments reduce heat gain more effectively than clear glass, by reflecting and absorbing more heat. Generally, the darker the treatment, the more effective it is at reducing heat gain.
- They are useful for east and west facing windows that have views and areas where other shading systems may not be practical.

## PROTECTING ROOF WINDOWS, CLERESTORY WINDOWS AND SKYLIGHTS

Skylights, clerestory windows and roof glazing are useful for letting in light, but can also cause major problems with your home's comfort levels.

- Double glazing is often the easiest way to reduce heat losses through these windows. However, double glazed skylights or roof glazing can still lose up to ten times more heat than an insulated ceiling of equivalent size.
- An unvented diffuser fitted at ceiling level will reduce down-draughts from skylights. It prevents warm air from rising, only to cool on contact with the cold surface of the skylight then fall back into the room.
- Summer shading can be achieved using external roller blinds, eaves over north facing clerestory windows and adjustable louvres.

- Some skylights have angled louvres integrated into the diffuser or the double glazing unit. These provide summer shading and natural daylight and, if positioned correctly, winter sunlight.

## YOUR ROLE

Once you have installed effective internal and external window treatments, use them!

### In winter:

- All windows and glass doors should be well sealed to prevent unwanted draughts and dust entering the home.
- On sunny winter days, leave north facing windows uncovered to let in the sunlight. This will supplement your existing heating system.
- Close coverings on cold cloudy days and at night to retain warmth inside your home.

### In summer:

- Shade windows from sunrise to sunset, keeping the sun out of the house for as long as possible.
- Keep all doors and windows closed until it becomes hotter inside than outside. Then open windows and use the breeze to flush the hot air out.
- Keep the house open through the night to cool it down for the next day.

---

## OTHER PUBLICATIONS IN THIS SERIES

- *A Guide to Home Insulation*
- *A Guide to Energy Efficient Home Design*
- *A Guide to Landscaping for Energy Efficiency*
- *A Guide to Cooling Systems*
- *A Guide to Hot Water Systems*
- *How to Save on Your Energy Bills*
- *A Home Energy Audit*

## NEED MORE HELP?

The Department of Mines and Energy can also provide information on energy efficient house design and other home energy efficiency measures.

For further information, call 1300 369 388 or visit the Department of Mines and Energy web site at [www.dme.qld.gov.au](http://www.dme.qld.gov.au)

